

Zubehör/Accessories/Accessoires

A Einfachlaufschiene Alu, zum Kleben

Single running track aluminium, for glue fixing
Rail de roulement simple en alu, à coller

B Einfachlaufschiene Alu, mit Drehriegel (nicht für Hartholz/MDF)

Single running track aluminium, with swivel lug (not for hard wood/MDF)
Rail de roulement simple en alu, avec verrou (pas pour bois dur/MDF)

C Einfachlaufschiene Alu, gelocht, zum Schrauben

Single running track aluminium, pre-drilled, for screw fixing
Rail de roulement simple en alu, perforé, à visser

Schienenendstück, Kunststoff grau, mit Drehriegel

Track end piece, plastic grey, with swivel lug
Pièce d'extrémité, plastique gris, avec verrou
(nicht für Hartholz/MDF, not for hard wood/MDF, pas pour bois dur/MDF)

Schienenendstück, Kunststoff grau, zum Schrauben

Track end piece, plastic grey, for screw fixing
Pièce d'extrémité, plastique gris, à visser

D Doppellaufschiene Alu, gelocht, zum Schrauben

Double running track aluminium, pre-drilled, for screw fixing
Rail de roulement double en alu, perforé, à visser

E Doppellaufschiene, Alu eloxiert, gelocht, zum Aufschrauben

Double running track, aluminium anodized, pre-drilled, surface mounted
Rail de roulement double en alu, anodisé, perforé, à visser en applique

Führungsschiene, Kunststoff anthrazit, 7 mm

Guide track, plastic anthracite, 7 mm
Rail de guidage, en plastique anthracite, 7 mm

Gr./Size

Art. No.

2500 mm 053.3229.250

3500 mm 053.3229.350

6000 mm 053.3229.600

2500 mm 053.3227.250

3500 mm 053.3227.350

6000 mm 053.3227.600

2500 mm 053.3225.250

3500 mm 053.3225.350

6000 mm 053.3225.600

2x 053.3211.081

2x 053.3210.081

2500 mm 053.3226.250

3500 mm 053.3226.350

6000 mm 053.3226.600

2500 mm 053.3231.250

3500 mm 053.3231.350

6000 mm 053.3231.600

2500 mm 053.3012.250

3500 mm 053.3012.350

6000 mm 053.3012.600



Garnituren / Sets / Garnitures

2 Türen Doors Portes		No. 053.3220.071	
	4x		2x
	4x		2x
	1x		

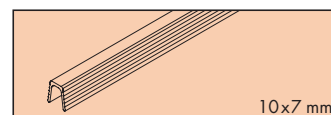
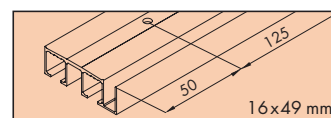
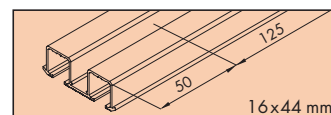
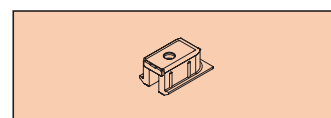
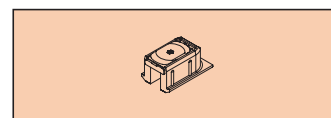
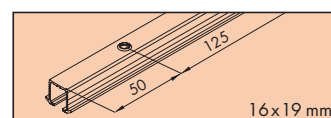
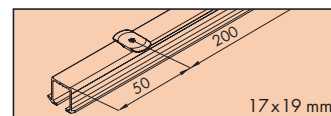
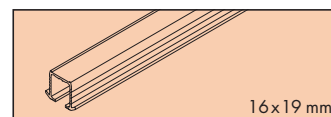

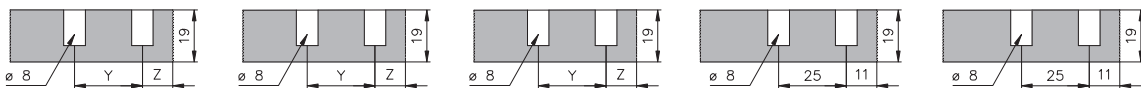
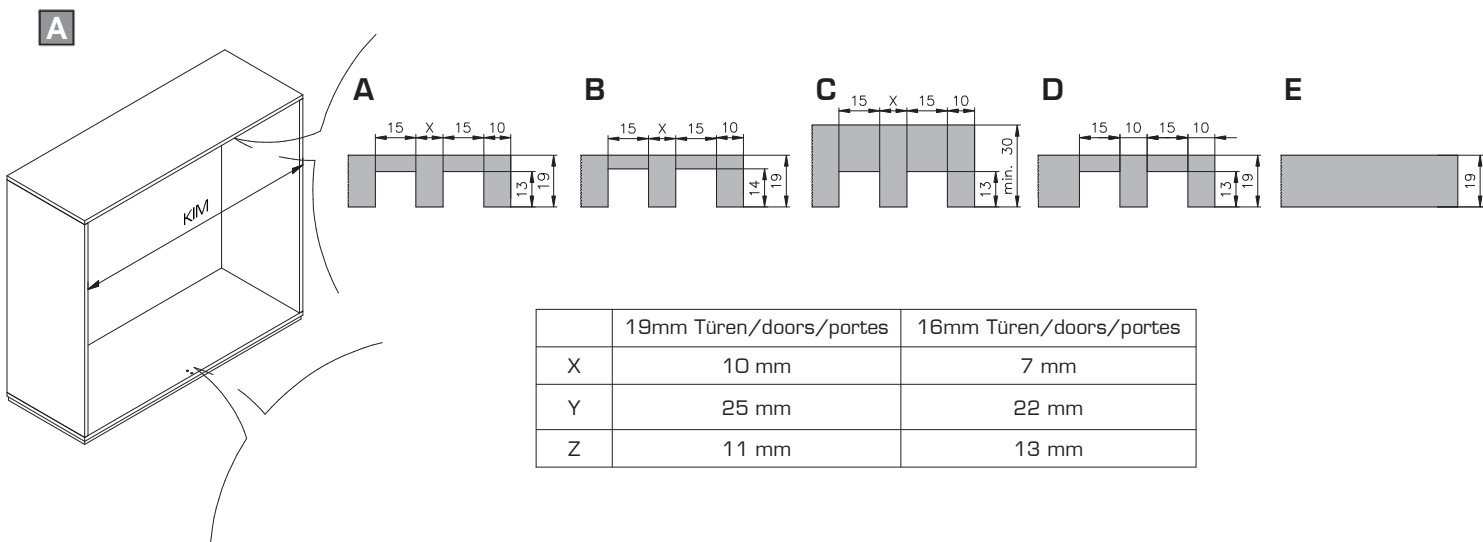

Befestigungsvarianten A - E / Mounting options A - E / Variantes de fixation A - E: 4

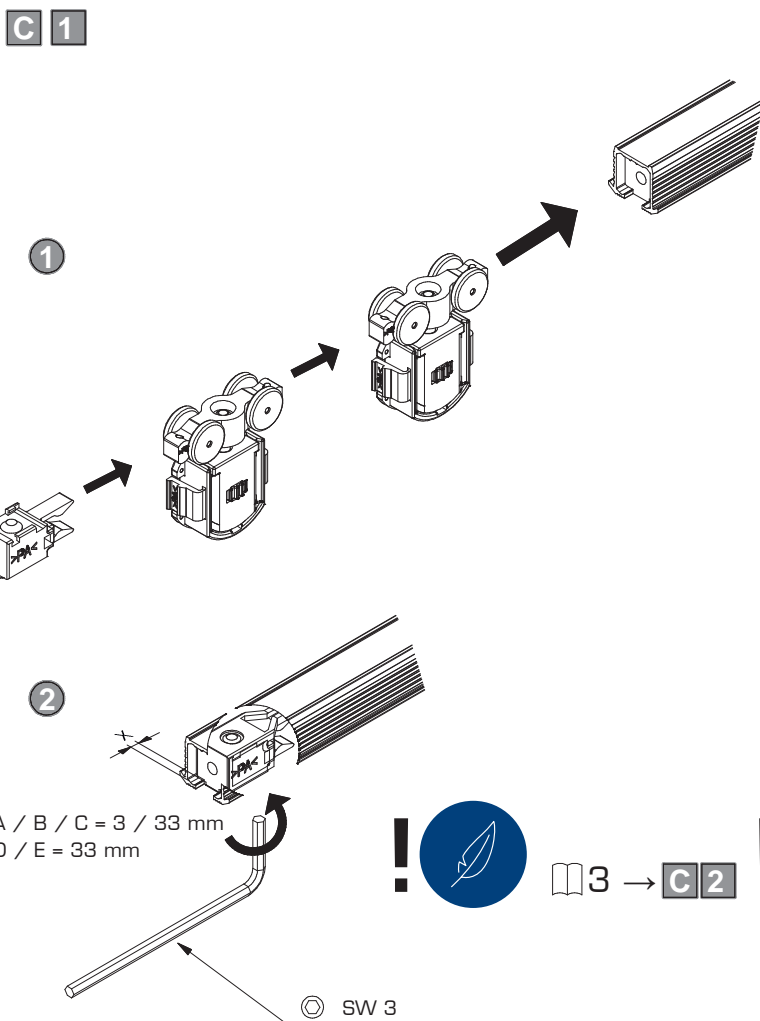
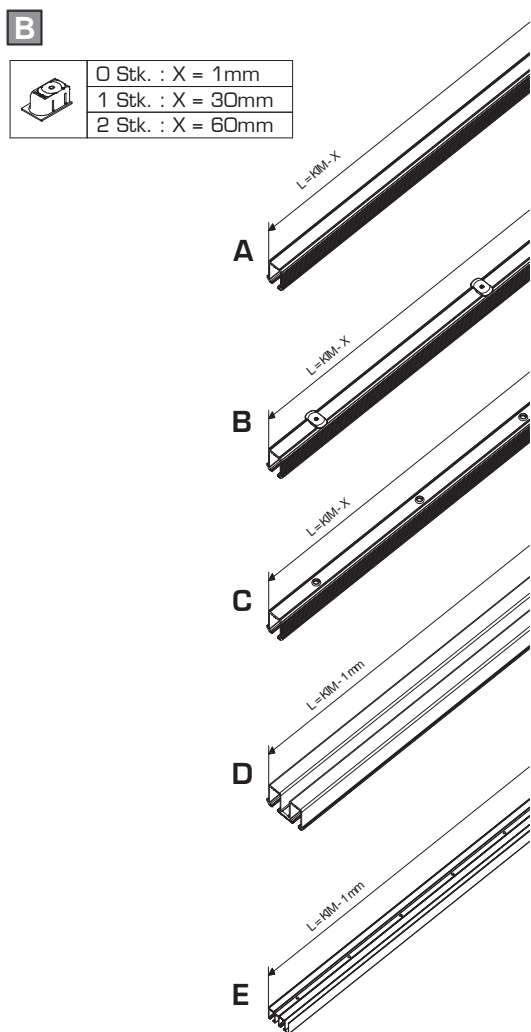

C 2

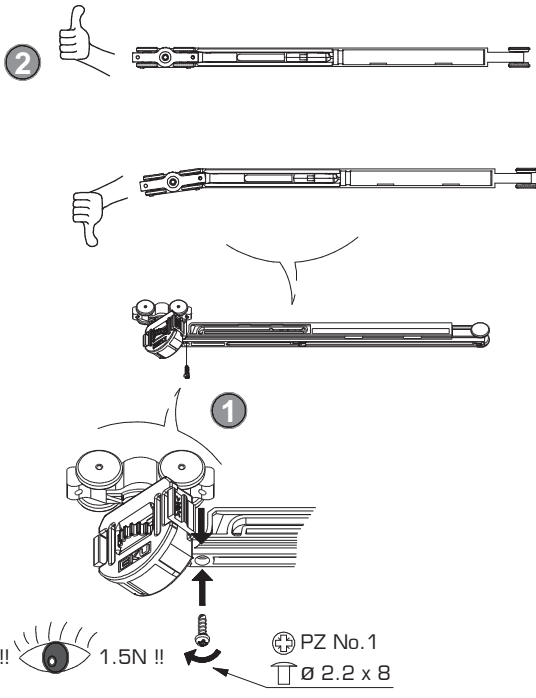

Empfehlung: Der Zugang zu den Dämpfungskomponenten sollte jederzeit möglich sein. Demontierbare Laufschienen oder Möbelkonstruktion entsprechend planen.

Recommendation: The access to soft-closing components should be possible at any time. Plan removable running tracks or furniture designs accordingly.

Recommandation: L'accès aux composants de l'amortisseur doit être possible à tout moment. Prévoir en conséquence des rails de roulement ou une constructions de meuble démontables.

Garnituren / Sets / Garnitures

No. 053.3332.XXX	
	2x
	2x
	2x

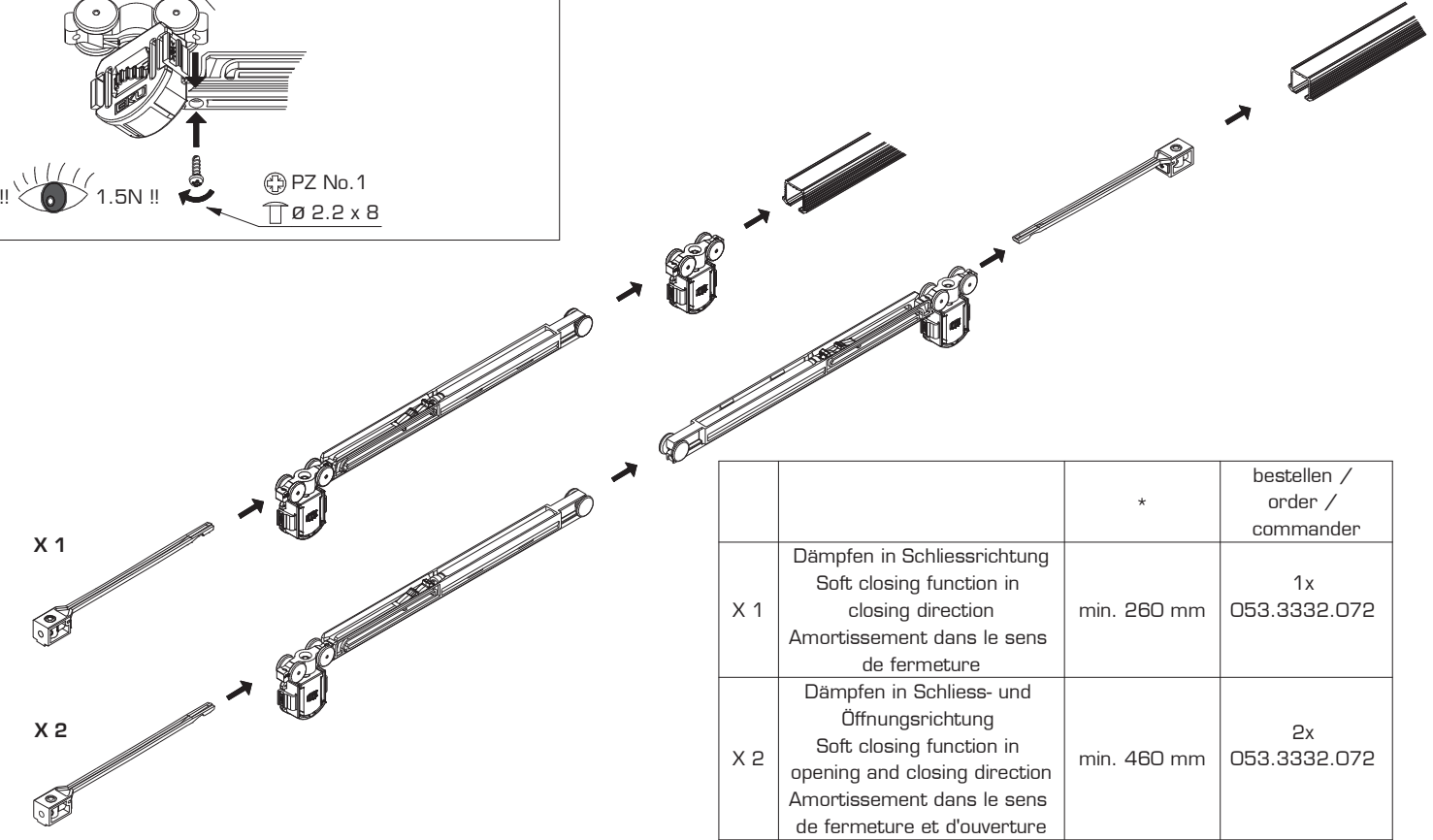

		*	bestellen / order / commander
X 1	Dämpfen in Schliessrichtung Soft closing function in closing direction Amortissement dans le sens de fermeture	min. 260 mm	1x 053.3332.072
X 2	Dämpfen in Schliess- und Öffnungsrichtung Soft closing function in opening and closing direction Amortissement dans le sens de fermeture et d'ouverture	min. 460 mm	2x 053.3332.072

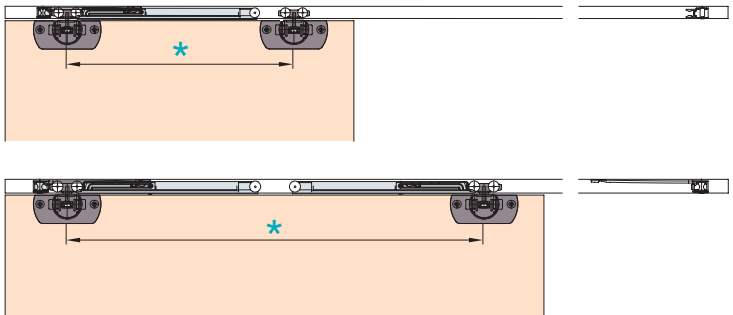
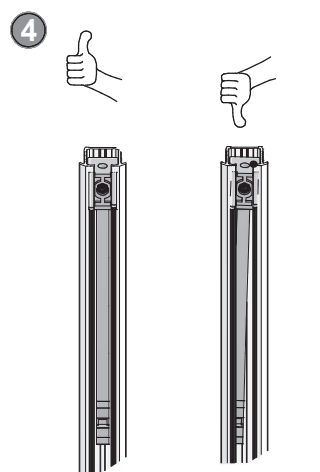
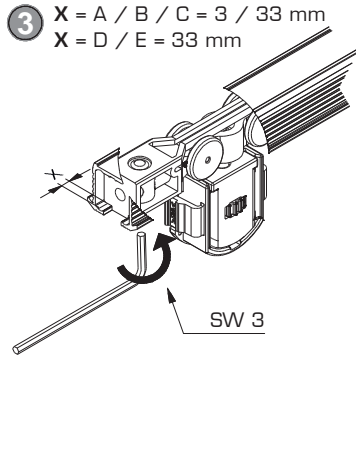

D



***Nicht für Hartholz/MDF**
 Not for hard wood/MDF
 Pas pour bois dur/MDF

A / B / C = **Hartholz/MDF** - Hard wood/MDF - Bois dur/MDF = mind. 30mm
 Art. No. 053.3210.081/053.3210.082

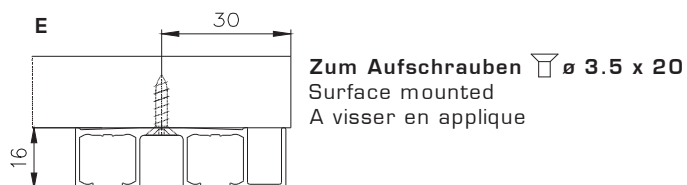
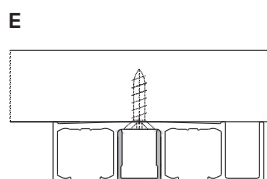
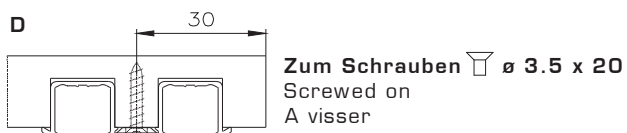
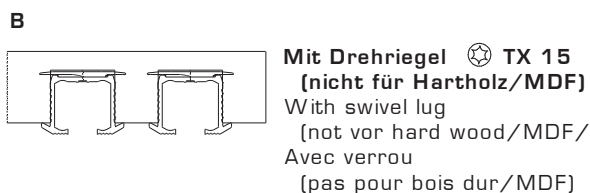
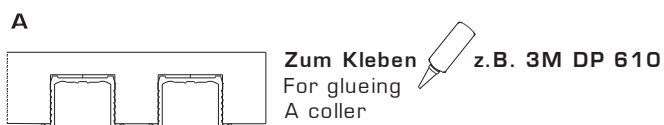
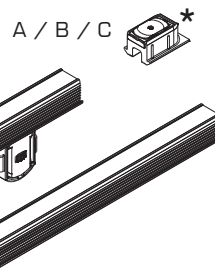
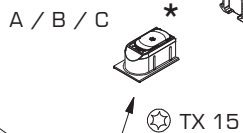
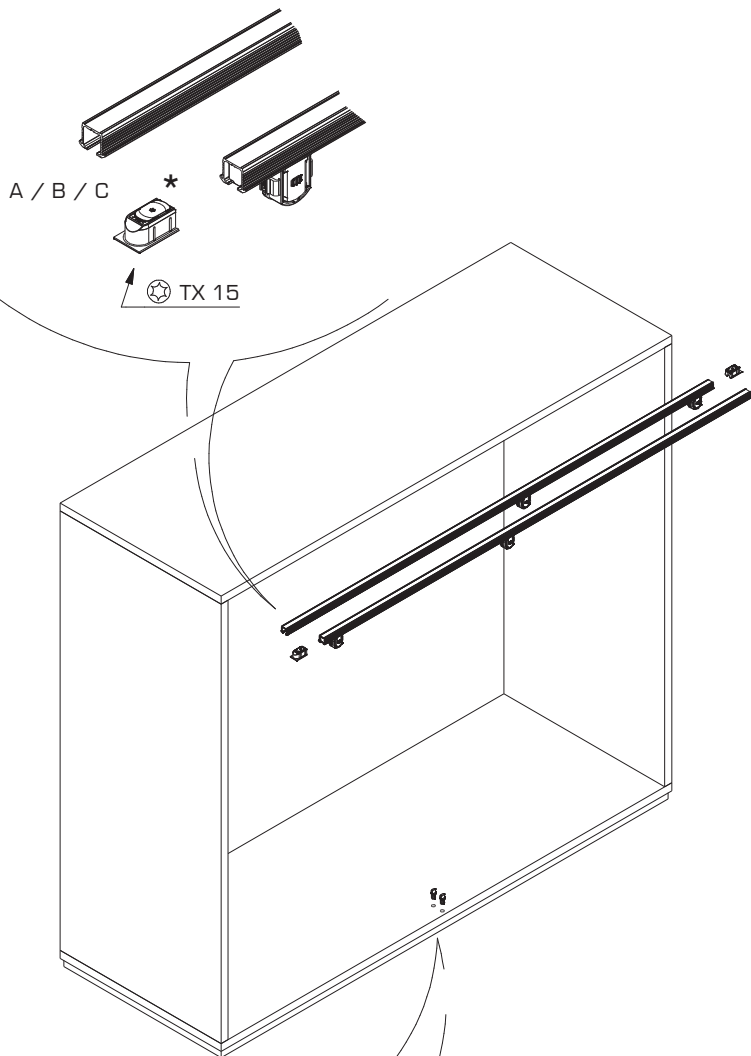

Optional/optional/optionnel
 Art. No. 042.3086.xxx

E

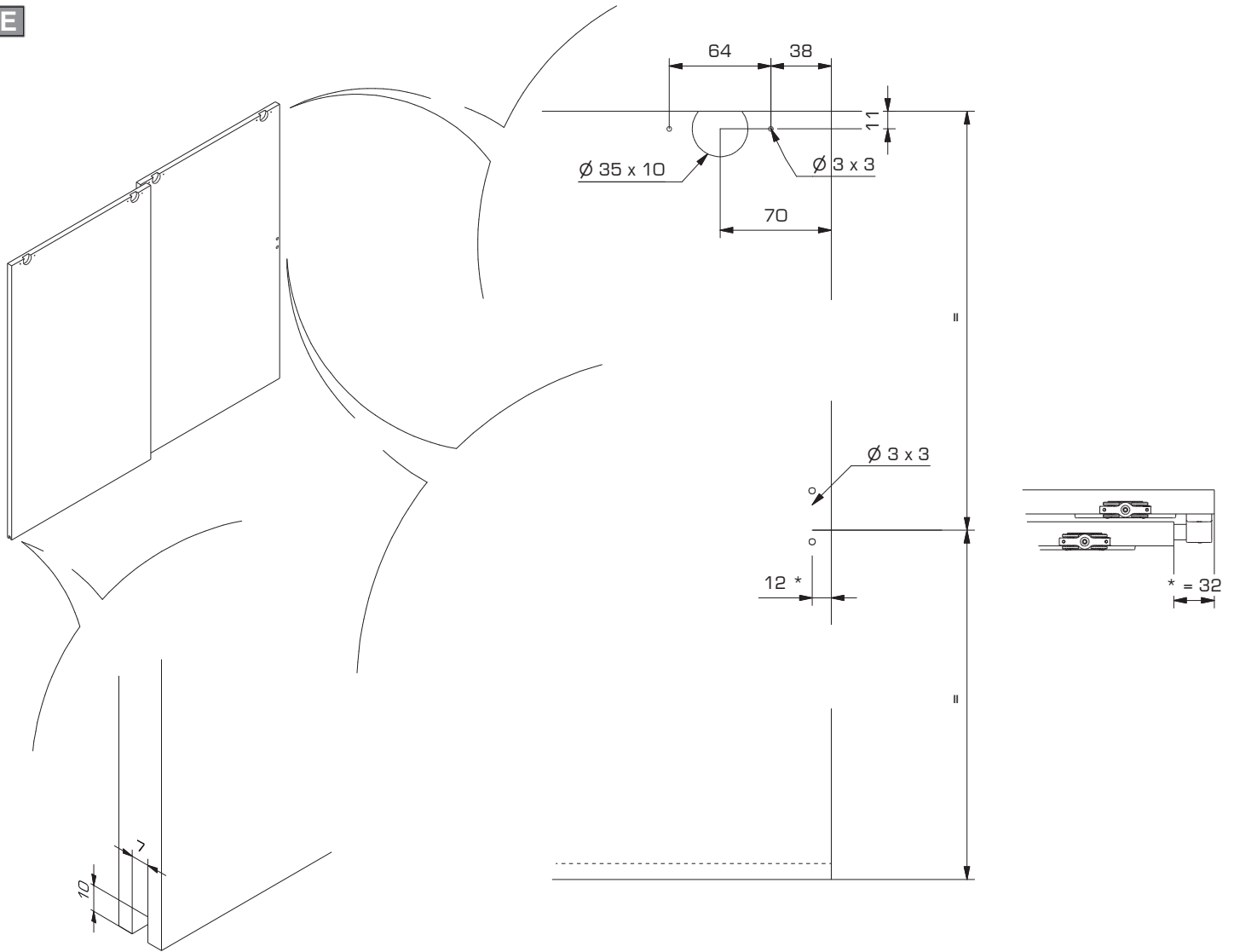

F

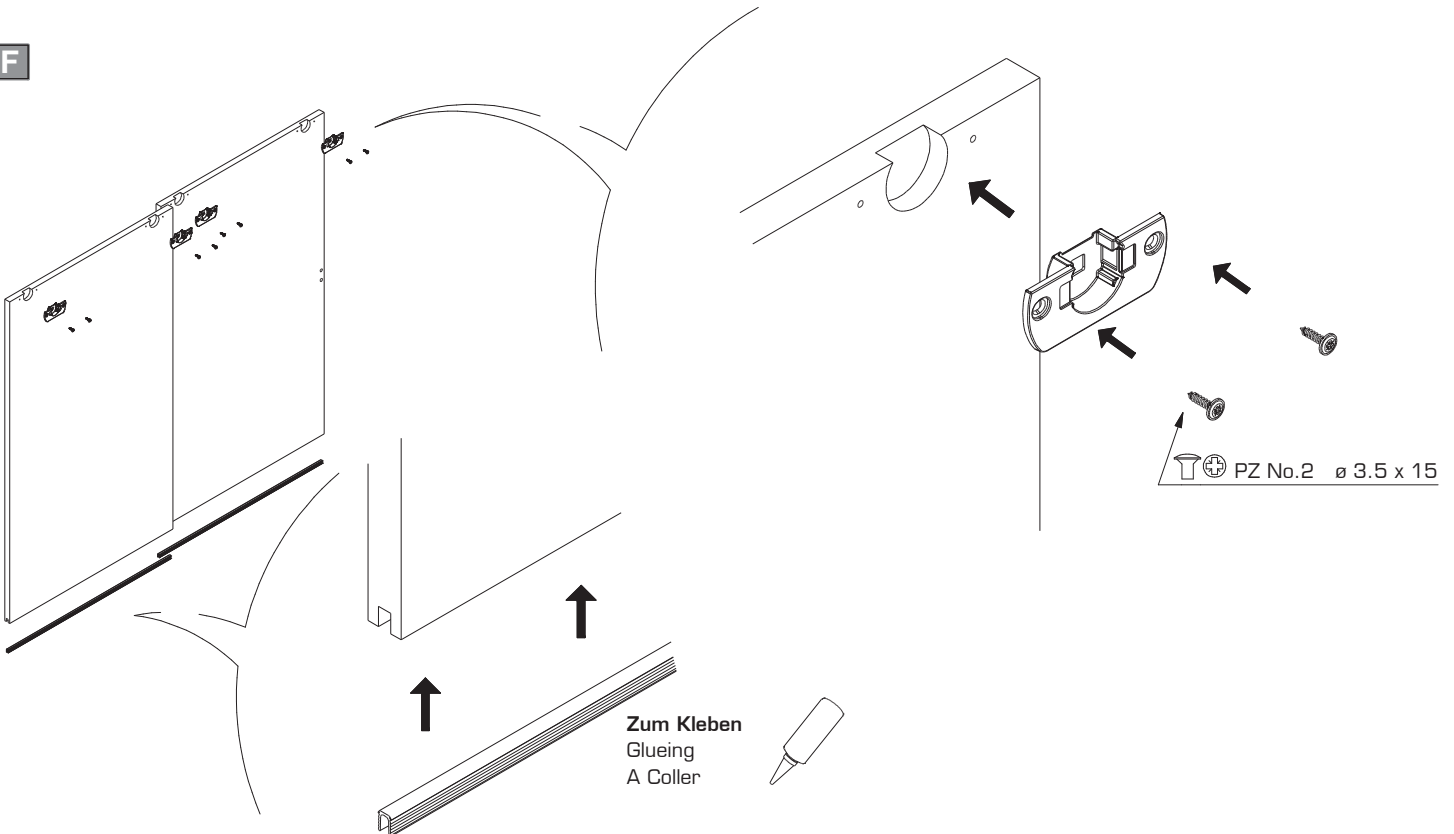

G

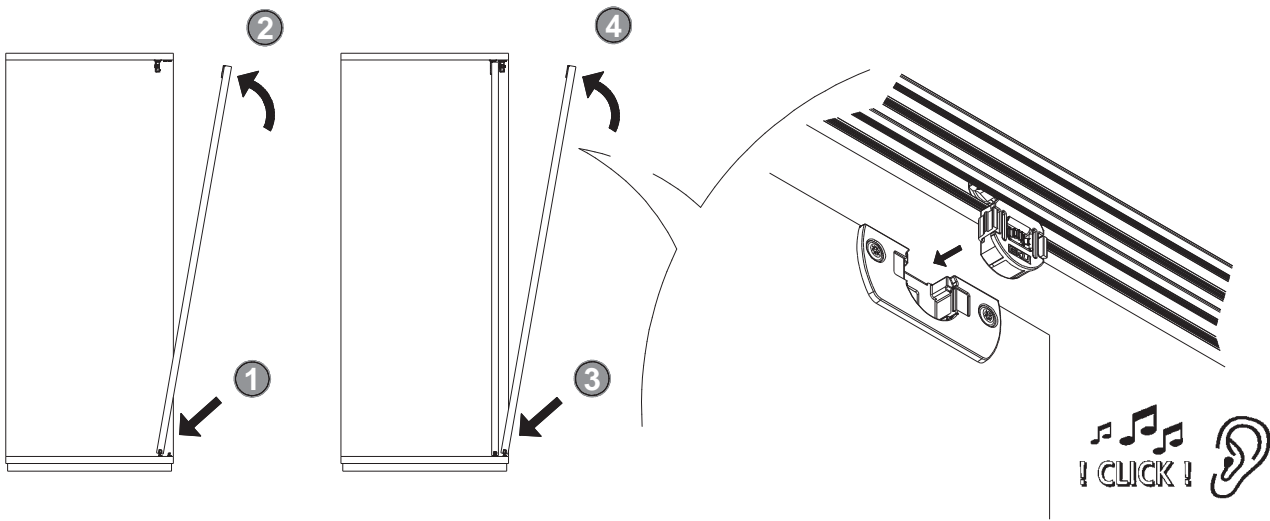

H

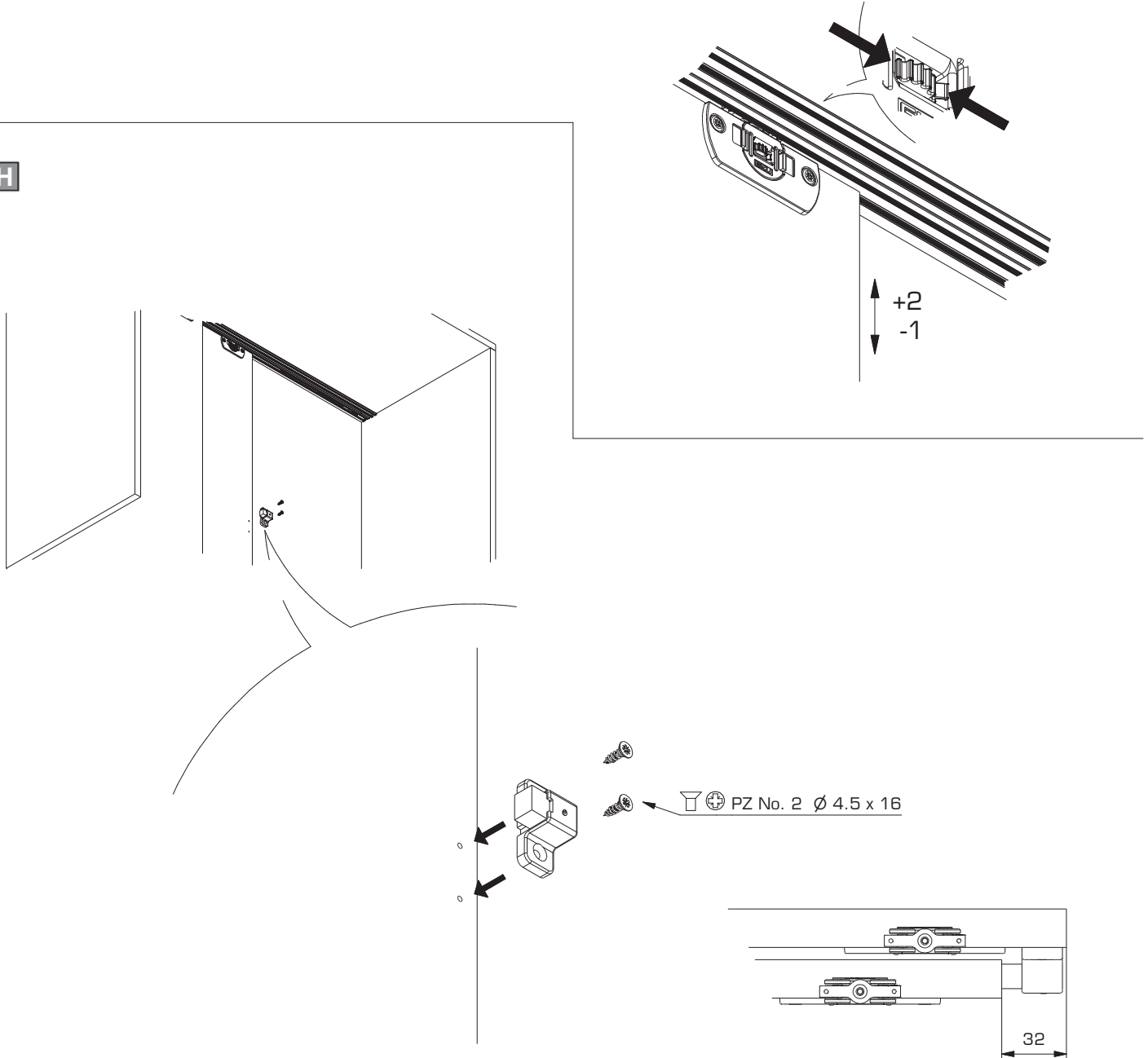

I Türdemontage
Door dismounting
Demontage de la porte

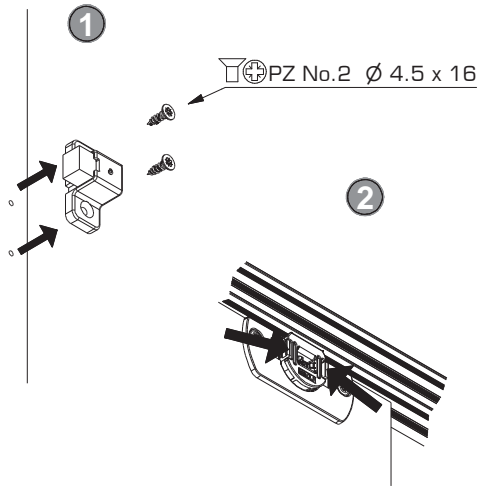

J Optional
Optional
Optionnel

Bei zurückversetzter Seitenwand Stopper unten setzen

Where doors overlap sidepanels, set stopper at the bottem
Placer la butée en bas si la paroi latérale est décalée par rapport à la porte

Art. No. 053.3104.171 VE=2

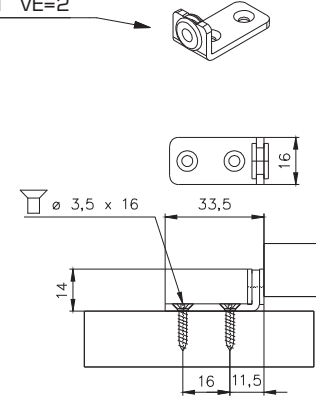

Einbaubeispiele / Mounting examples / Exemples de montage

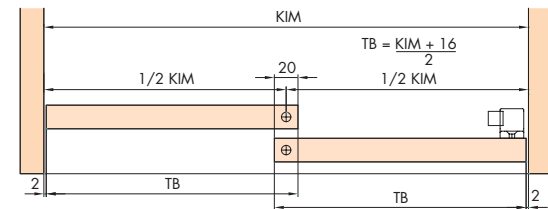
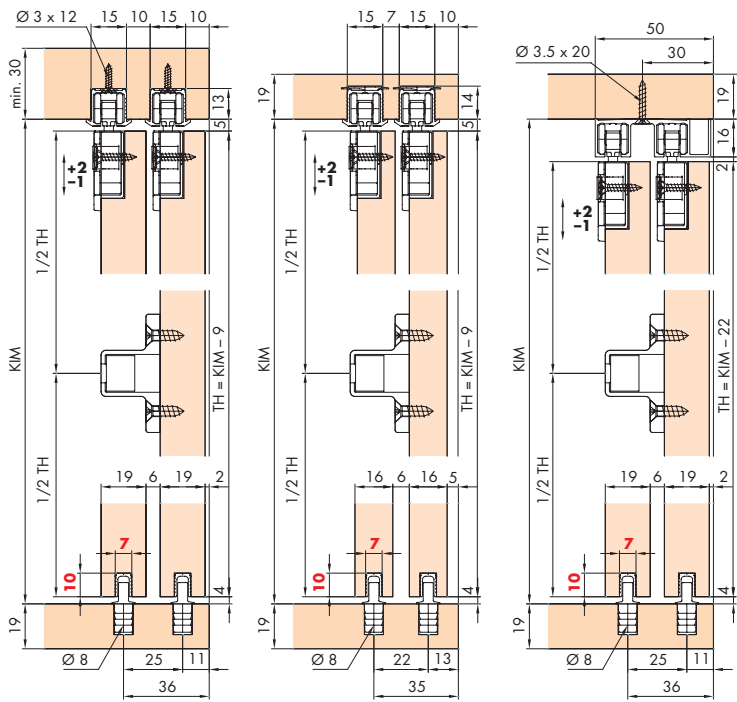

D/E Schienenlänge / Track length / Longueur du rail
KIM - 1

A/B/C Schienenlänge / Track length / Longueur du rail
KIM - (2x30)

